

# Nanoenergetics

## Sample Scale Instrumentation:

- Silicon micromachining has radically changed the definition of instrumentation.
- Advanced understanding of material properties allows for the creation of new technologies.
- Instrumentation is now in the environment of the sample.
- Biocalorimetry:
  - Time resolved measurements of protein folding.

## Specific Heat:

These measurements are used to test and develop models for materials of interest to condensed matter physics.

## Research at UCSD:

- Fe/Cr: density of states independent of field, GMR not due to changes in DOS
- Gd-Si: non-trivial nature of the conduction electron-local moment interactions (excess entropy); importance of magnetic moments in semiconductors
- CoO: finite size effects in antiferromagnets, important to recording industry
- LCMO/  
LSMO: High resolution critical studies showed a transition from first to second order through a tricritical point, not usually seen in ferromagnets

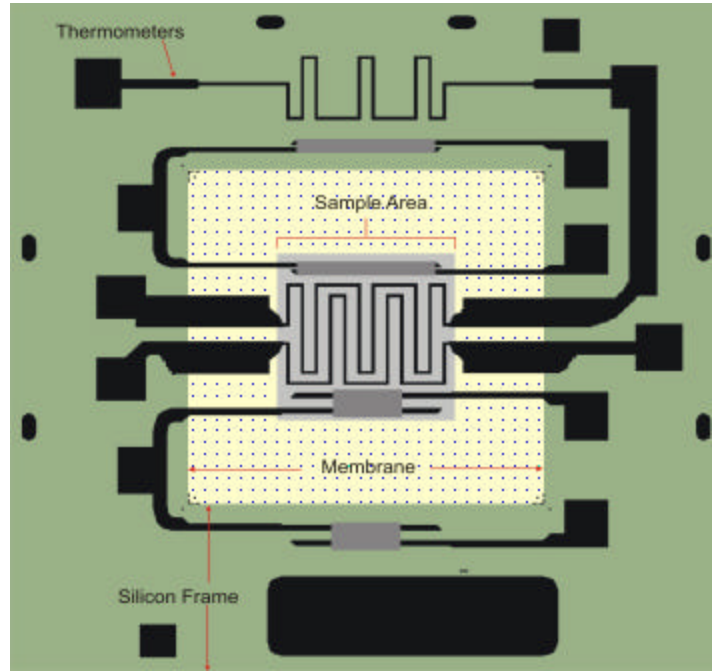

## Specifications:

Temperature Range:	.3K - 500°C
Energy Resolution:	20 fJ
Power Resolution:	20 pW
Dimensions:	1cm × 1cm
Membrane Thickness:	200 nm
Membrane Aspect Ratio:	$2.5 \times 10^4$

## Collaborators:

Los Alamos National Lab  
BYU  
UC Davis  
Max Plank Institute