

On the feasibility of detecting an Aharonov-Bohm phase shift in neutral matter

Yuki Sato and Richard Packard

Department of Physics, University of California, Berkeley, California 94720, USA

E-mail: ysato@berkeley.edu

Abstract. It has been predicted that, in the presence of combined radial electric field and axial magnetic field, superfluid ^4He in a torus will have a persistent current in its ground state. This surprising result arises from non-cancellation of the Aharonov-Bohm phase shifts associated with the opposite charges in the induced electric dipole moment of the neutral ^4He atoms. We briefly review this prediction and describe our proposed experiment. In this feasibility study we show that by applying laboratory accessible electric and magnetic fields, a superfluid ^4He interferometer (SHeQUID) will have sufficient sensitivity to conclusively determine whether or not the predicted physical phenomenon exists.

1. Introduction

In 1959 Aharonov and Bohm predicted [1] that electrons traveling outside a perfect solenoid would exhibit observable interference effects even though no classical force (but only a vector potential) exists in the spatial region traversed by the electrons. Subsequent experiments [2] proved the prediction to be correct. In 1994, M. Wilkens predicted [3] that a neutral particle with a permanent electric dipole moment would exhibit an Aharonov-Bohm (AB) type phase shift when moving in a magnetic field. However, the experiment to test this theory has been difficult to perform for the predicted effect requires a radial magnetic field. In 1995, Wei et al. predicted [4] a similar topological phase shift and suggested an experimental arrangement to test their prediction. The physical configuration involves neutral particles with no permanent electric dipole moment moving in a plane containing a radial electric field and a uniform magnetic field perpendicular to it. The applied electric field induces an electric dipole in the particles that then exhibit an AB shift related to that suggested by Wilkens. Wei et al. pointed out further that when the particles used are quantum coherent superfluid ^4He in a torus, the topological phase shift should result in a superfluid persistent current in the ground state of the condensate. We briefly review this prediction and then describe our proposed experiment in which we intend to use a superfluid ^4He quantum interference device (SHeQUID) [5] to investigate the predicted phenomenon. We discuss the experiment's feasibility and significance.

2. Prediction

The existence of the AB phase shift in neutral matter can be seen from analyzing the situation shown in Figure 1. More complete and detailed derivation using the Lagrangian formalism (as well as its connection to the path integral approach briefly outlined below) is presented in ref [4].

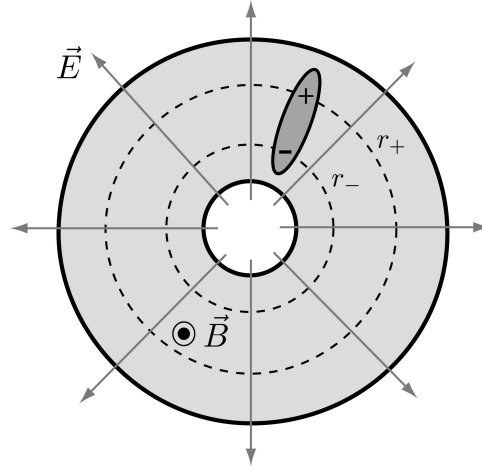

Figure 1. The geometry of interest. Quantum coherent matter (in this case BEC condensed superfluid ^4He) is confined to a toroidal container that is positioned in a radial electric field and an axial magnetic field.

As a matter wave propagates along some path, its phase evolves in time and space according to the Feynman path integral formulation. Certain topology changes the path integral and gives rise to a change in the accumulated phase. A line integral gives the shift in quantum phase due to the change in the particles momentum along its trajectory.

$$\Delta\phi = \frac{1}{\hbar} \int_{path} \Delta\vec{p} \cdot d\vec{l}. \quad (1)$$

The radial electric field polarizes the neutral particle and induces an electric dipole. This dipole d can be thought of as a pair of equal and opposite charges q at distances r_+ and r_- with respect to the symmetry axis of the radial electric field: $d = q(r_+ - r_-)$. As these charges traverse closed circular paths (of radii r_+ and r_-) in a region where the magnetic field exists, they individually experience a shift in quantum phase according to Equation 1. The phase shift for the positive charge is given by

$$\Delta\phi_+ = \frac{1}{\hbar} \oint_{path} \Delta\vec{p} \cdot d\vec{l} = \frac{1}{\hbar} \oint_{path} q\vec{A} \cdot d\vec{l} = \frac{1}{\hbar} \int_{area} q\vec{B} \cdot d\vec{S} = \frac{1}{\hbar} qB\pi r_+^2, \quad (2)$$

where \vec{A} is the vector potential corresponding to magnetic field \vec{B} , and $d\vec{S}$ is a differential area vector. Similarly, the phase shift for the negative charge is

$$\Delta\phi_- = -\frac{1}{\hbar} qB\pi r_-^2. \quad (3)$$

The total phase shift, which is the sum of the two, is then

$$\Delta\phi = \frac{qB\pi(r_+^2 - r_-^2)}{\hbar} = \frac{\pi B(r_+ + r_-)q(r_+ - r_-)}{\hbar} = \frac{2\pi Brd}{\hbar}, \quad (4)$$

where r is the radius of the particle's trajectory. The dipole moment induced by an electric field is $d = \alpha E$ where α is the particle's polarizability. If the radial electric field is created between concentric cylindrical electrodes (characterized by inner radius a and outer radius b) biased at potential difference V , $E = V/r \ln(b/a)$ in cylindrical coordinates. \vec{B} is pointed along the cylinder axis. The phase shift is then given by

$$\Delta\phi \approx \frac{2\pi\alpha BV}{\hbar \ln(b/a)}. \quad (5)$$

If the superfluid is used, its velocity is related to the phase gradient by $v_s = (\hbar/m) \nabla \phi = \hbar\Delta\phi/2\pi mr$, where m is the helium atomic mass and r is the radius of a torus. Thus the predicted phase difference of Equation 5 corresponds to a persistent superfluid current in the torus as pointed out by Wei et al.

3. Experimental plan

Figure 2 shows the conceptual plan of the experiment. The sense loop of a superfluid ^4He quantum interference device (SHeQUID) plays the role of a torus depicted in Figure 1. The details on SHeQUIDs are described elsewhere [5]. The loop in Figure 2 contains two counter-wound parts. This configuration will remove phase shifts caused by rotation-noise around the axis of the apparatus. Both halves of the loop are embedded in individual coaxial capacitors (only one set is shown). The outer cylindrical electrodes will fit inside the bore diameter of a superconducting magnet capable of producing fields (parallel to the cylinder axis) as large as 7T. The capacitors may be biased with voltage differences $\pm V$. The vertical arms connecting the helical coil to the superfluid Josephson weak links will enclose sufficient area so that reorientation of the entire apparatus with respect to the north-south axis of the Earth will sweep out approximately one half cycle of the Sagnac interference pattern [5]. This will permit one to bias the interferometer at the steepest part of the interference pattern where there is the greatest sensitivity to external phase shifts. One could also install a heat current pipe in the loop to inject phase bias to achieve this [6].

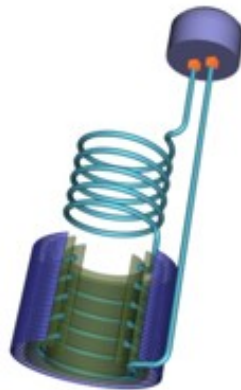

Figure 2. A sketch of the proposed AB experiment. A counter-wound helical interferometer “loop” is embedded within cylindrical capacitors in the bore of a high field magnet.

The polarizability of helium is $2 \times 10^{-41} \text{Fm}^2$. For concentric cylinders with b/a ratio of 1.1, the predicted phase shift from Equation 5 is $1.3 \times 10^{-5} BV$ radians. If one uses a magnet that generates 7T and applies 5kV between the cylindrical electrodes, $\Delta\phi \sim 0.5$ radians for a single loop. A single turn of our current superfluid interferometers [7] can detect phase shifts ~ 15 times smaller than this predicted result in only one second of measuring time. In two minutes integration time, the phase shift will be observed with a S/N of over 100. If the interferometer contains more turns, the S/N is proportionally increased. Thus if the prediction of Wei et. al. is correct, the phase shift will be observed. By including approximately six turns in each half of the loop, the phase shift will be $\sim \pi$ thus sweeping out an entire cycle of the interference

pattern. Seeing one complete interference cycle makes the most convincing test of the prediction. If a long sense arm loop poses problems due to its large hydrodynamic inductance or acoustic resonance excited in it, one could, for example, repeat the measurements while using the heat current phase bias to shift the starting location in the interference curve (before applying the E or B field) to eventually map out the whole interference pattern.

4. Significance

If the atoms are already in the superfluid state and the fields are subsequently turned on, one may deduce classical forces exerted on the particles to impart the kinetic energy associated with the flow. However if the E and B fields already exist when the liquid is in the normal state (above the BEC transition temperature of 2.17K) and the liquid is subsequently cooled into the superfluid state, we are faced with a necessity to understand how a change in temperature can impart net kinetic energy and angular momentum to the fluid to flow around the interferometer path. This is an intriguing question that perhaps cannot be answered in the context of classical physics.

There are other fundamental questions that may be clarified in this type of experiment. In the conventional description of AB effects, quantum wave packets traverse the two paths of an interferometer. It is the recombination of the packets that displays the interference. This is a valid picture for free-atom interferometers or electron beams used for AB type experiments, since in these instruments the particles, in a classical sense, actually do traverse the region where electromagnetic potentials exist. In contrast in the superfluid ^4He interferometer, although the helium atoms very slowly drift due to the induced phase gradient, ($v_s \sim 2 \times 10^{-5}\text{cm/s}$ for a $\pi/2$ phase shift and a loop circumference of 13cm) they do not physically traverse the interferometer path on the time scale of the measurement, which can be as short as a single Josephson oscillation cycle $\sim 10^{-3}\text{sec}$. Instead, the space filled with superfluid ^4He is described by a single macroscopic wavefunction with a phase that depends on time and space. All the $\sim 10^{21}$ atoms are in a single macroscopic entangled state, which is globally determined by the fields covering the region occupied by the fluid. The successful observation of the predicted phase shift in superfluid helium may suggest that the AB paradigm is more general than that needed to describe free particle propagation.

Full discussion of the derivation presented in ref [4] is beyond the scope of this manuscript. However we point out that comparing the magnitude of the actual signal with the expected size (if the effect is there) can shed light on the validity of physical pictures used to describe or motivate the predicted phenomenon. If the prediction of Wei et al. is correct, it will complete a triad of phenomena including the original Aharonov-Bohm shift (charged particle in a magnetic vector potential), the Aharonov-Casher shift (a magnetic moment moving in an electric field), and now a non-magnetic neutral particle moving in crossed E and B fields. It will also probe questions related to the creation of the quantum ground state by temperature variations alone. Since the individual helium atoms in this entangled state do not physically move through the space containing the fields, the experiment may suggest a more general interpretation of the Berrys phase phenomenon.

References

- [1] Aharonov Y and Bohm D 1959 *Phys. Rev.* **115** 485
- [2] Shambers R G 1960 *Phys. Rev. Lett.* **4** 344
- [3] Wilkens M 1994 *Phys. Rev. Lett.* **72** 5
- [4] Wei H, Han R and Wei X 1995 *Phys. Rev. Lett.* **75** 2071
- [5] Hoskinson E, Sato Y and Packard R E 2006 *Phys. Rev. B* **74** 100509(R)
- [6] Sato Y, Joshi A and Packard R E 2007 *Appl. Phys. Lett.* **91** 074107
- [7] Sato Y, Joshi A and Packard R E 2007 *Phys. Rev. Lett.* **98** 195302